

# **Installation Guide**

**Volatiles Interface for 6890 Gas Chromatograph  
Accessory G2319A**



**Agilent Technologies**

© Agilent Technologies, Inc. 2001  
All Rights Reserved. Reproduction,  
adaptation, or translation without  
permission is prohibited, except as  
allowed under the copyright laws.  
Part No. G2319-90107  
First edition, DEC 2001

Replaces part number G2319-90100;  
*6890 GC Volatiles Interface  
Installation and Operating Guide.*  
Printed in USA

### Safety Information

The 6890 Gas Chromatograph (GC) meets the following IEC (International Electrotechnical Commission) classifications: Safety Class 1, Transient Overvoltage Category II, and Pollution Degree 2.

This unit has been designed and tested in accordance with recognized safety standards and designed for use indoors. If the instrument is used in a manner not specified by the manufacturer, the protection provided by the instrument may be impaired. Whenever the safety protection of the 6890 GC has been compromised, disconnect the unit from all power sources and secure the unit against unintended operation.

Refer servicing to qualified service personnel. Substituting parts or performing any unauthorized modification to the instrument may result in a safety hazard. Disconnect the AC power cord before removing covers. The customer should not attempt to replace the battery or fuses in this instrument. The battery contained in this instrument is recyclable.

### Safety Symbols

Warnings in the manual or on the instrument must be observed during all phases of operation, service, and repair of this instrument. Failure to comply with these precautions violates safety standards of design and the intended use of the instrument. Agilent Technologies assumes no liability for the customer's failure to comply with these requirements.

### WARNING

A warning calls attention to a condition or possible situation that could cause injury to the user.

### CAUTION

A caution calls attention to a condition or possible situation that could damage or destroy the product or the user's work.



Indicates a hot surface

### Electromagnetic compatibility

This device complies with the requirements of CISPR11. Operation is subject to the following two conditions:

1. This device may not cause harmful interference.
2. This device must accept any interference received, including interference that may cause undesired operation.

If this equipment does cause harmful interference to radio or television reception, which can be determined by turning the equipment off and on, the user is encouraged to try one or more of the following measures:

1. Relocate the radio or television antenna.
2. Move the device away from the radio or television.
3. Plug the device into a different electrical outlet, so that the device and the radio or television are on separate electrical circuits.
4. Make sure that all peripheral devices are also certified.
5. Make sure that appropriate cables are used to connect the device to peripheral equipment.
6. Consult your equipment dealer, Agilent Technologies, or an experienced technician for assistance.
7. Changes or modifications not expressly approved by Agilent Technologies could void the user's authority to operate the equipment.

### Recycling the Product

For recycling, send the product to:  
Agilent Technologies, Inc.  
2850 Centerville Road  
Wilmington, DE 19808-1610  
or  
Agilent Technologies Deutschland  
GmbH  
Hewlett-Packard Strasse 8  
76337 Waldbronn  
Germany

### Sound Emission Certification for Federal Republic of Germany

#### Sound Pressure

Sound pressure  $L_p < 65$  dB(A)  
During normal operation  
At the operator position  
According to ISO 7779 (Type Test)

#### Schalldruckpegel

Schalldruckpegel  $LP < 65$  dB(A)  
Am Arbeitsplatz  
Normaler Betrieb  
Nach DIN 45635 T. 19 (Typprüfung)

# Installation

---

## Caution

---

Before proceeding, refer to safety information on the inside front cover.

## Parts list

<b>Part</b>	<b>Quantity</b>
Torx screw for securing flow module to pneumatics carrier	1
Static-control wrist strap	1
O-Ring, 0.426-inch ID	2
Fastener captive screw M4 x 7 x 12mm	1
Wrist strap-disposable 4-LG 1-W	1
Pneumatics Top Cover	1
ROM set	1
VI insulation block	1
VI clamping plate	1
VI ship kit	1
VI heater zone assembly	1
Volatiles inlet	1
Volatiles alternate front trap assembly	1
Bracket valve trap	1

---

## Required tools

T-20 Torx screwdriver

## **System requirements**

The Volatiles Interface has the following firmware and software requirements:

- The 6890 GC firmware revision code must be A.03.08 or later. To check the GC firmware revision code, press [STATUS] and then [CLEAR] on the GC front panel.
- The 6890 GC ChemStation (if used) revision code must be A.04.02 or later. To check the ChemStation software revision, select the *About...* item in the Help menu.

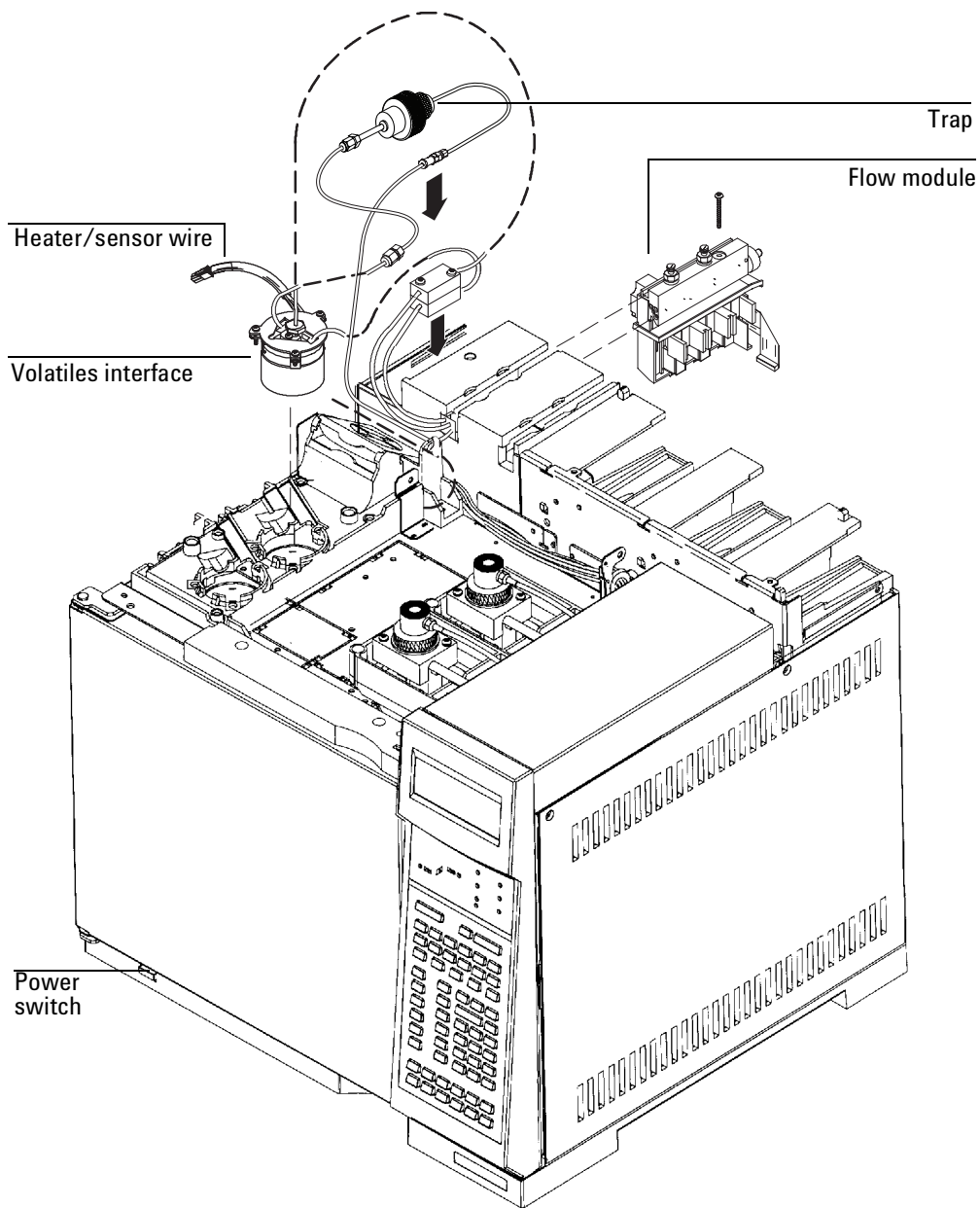

## Preparing the GC

---

**WARNING**

---

Hazardous voltages are present in the mainframe when the GC power cord is plugged in. Avoid a potentially dangerous shock hazard by unplugging the power cord before removing the side panels.

---

**Caution**

---

Prevent electrostatic voltages from damaging the GC by using precautions such as an ESD wrist strip.

1. Turn off the GC and unplug the power cord. Allow time for all heated zones to cool and then turn off supply gases at their sources.
2. Unsnap and lift off the pneumatics top cover.
3. Remove the RFI cover. Remove the screw with a T-20 Torx screwdriver, slide the cover to the left until it disengages from the top rear panel, and remove it.
4. Remove the inlet cover plate from the front or back position by loosening the two screws with a T-20 Torx screwdriver and sliding the plate up and off.
5. Loosen the five screws in the top rear panel with a T-20 Torx screwdriver.
6. Grasp the panel at each end and gently lift it up and then away from the GC. Be careful not to disrupt the supply tubing.  
Do not retighten the screws.
7. Remove columns and hardware from column cover.

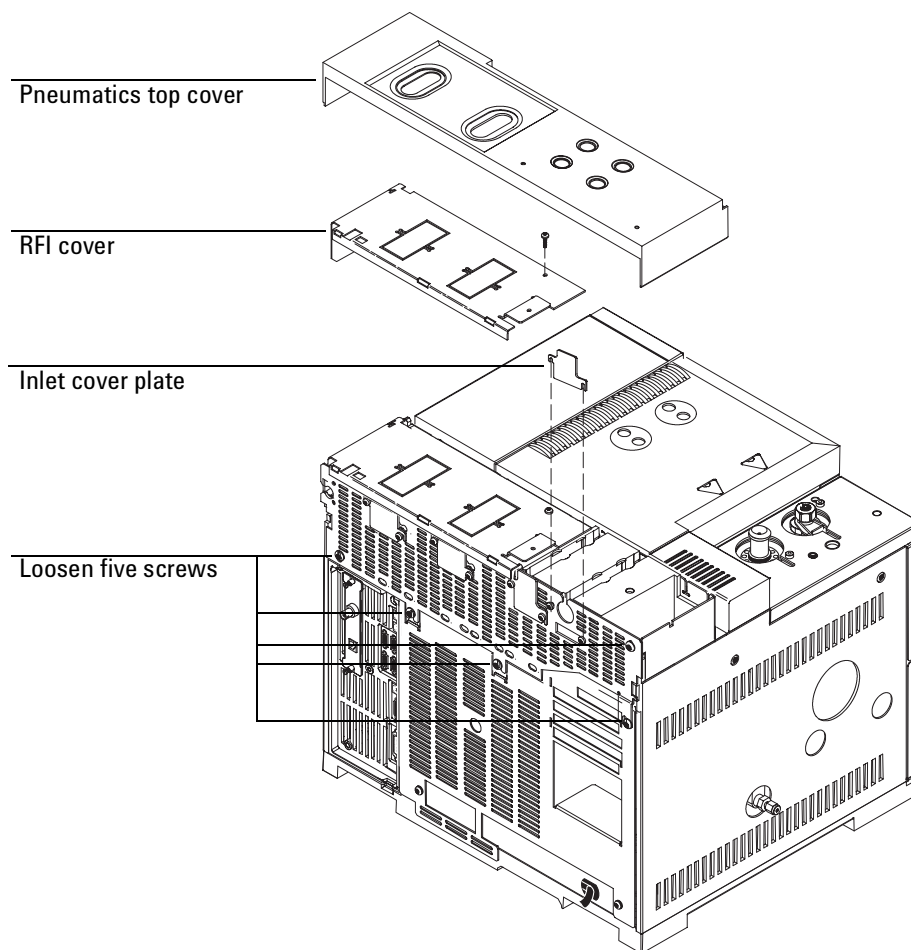

8. Raise the gray plastic top cover (with the holes and ventilation slots) to the vertical position. Examine the hinge in the right rear corner.
  - **Early 6890 models.** The hinge is a metal bracket attached to the oven top. Pull the clip at its top toward you to release the hinge pin. Push the pin to the left to release the cover. Raise the right side of the cover and remove it.
  - **Current 6890 models.** Tilt the cover to the left and remove it.

Installation  
Preparing the GC

9. Remove the left side cover by loosening the two screws with a T-20 Torx screwdriver, sliding the cover to the rear of the GC, and lifting off. Repeat for the right side cover.
10. Remove the fan cover.
  - a. Loosen the screw on the right side of the fan cover.
  - b. Slide the cover to the right to disengage it from the mounting post.
  - c. Lift the cover up and off.
11. If installed, remove the ALS tray, injector, and tray mounting bracket.
12. Remove the inlet cover. Loosen the five captive screws with a T-20 Torx screwdriver until you are able to lift off the cover.

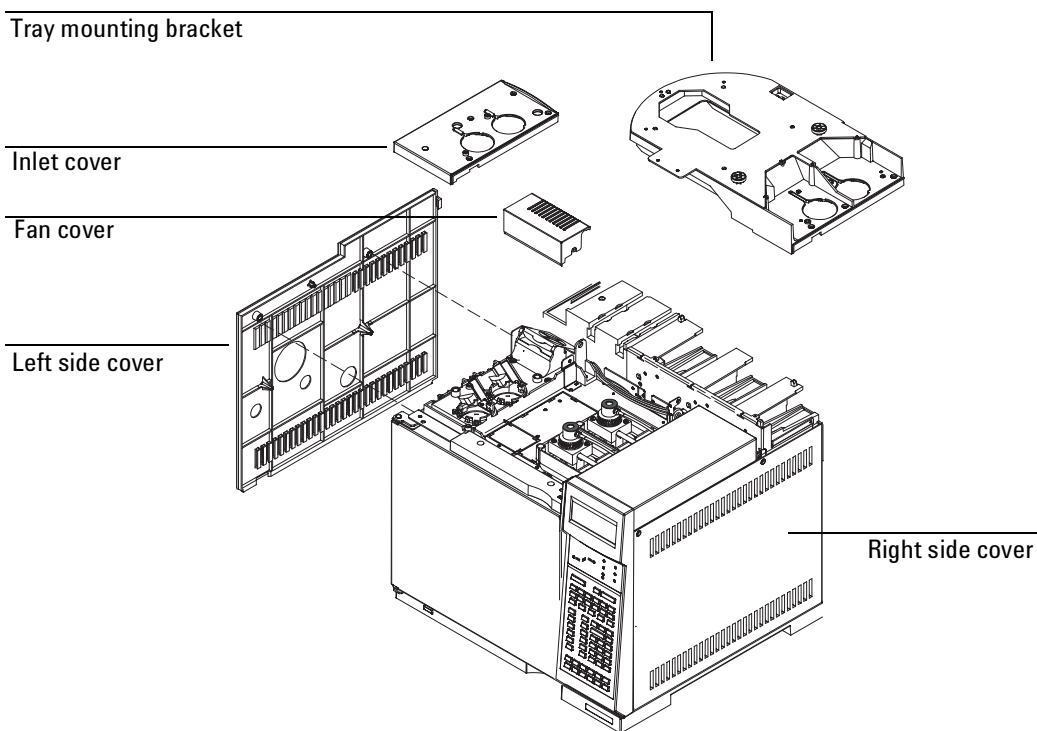



## Installing the flow module

---

### Caution

---

Board components can be damaged by static electricity; use a properly grounded static control wrist strap when installing the flow manifold.

**The gas lines from the flow module to the volatiles interface are assembled at the factory. Do not disconnect them.**

1. From the back of the GC, locate the pneumatics carrier.

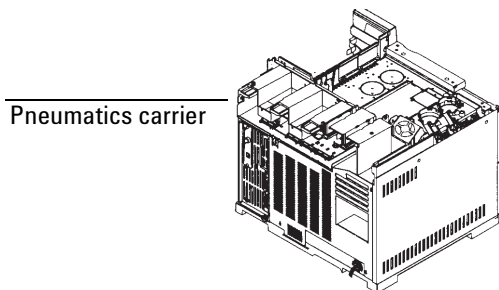

2. If you are installing an inlet in the back position and there is an inlet installed in the front position, unplug the ribbon cable from the pneumatic control board. Unlock the connector by pushing the tabs away from the center.

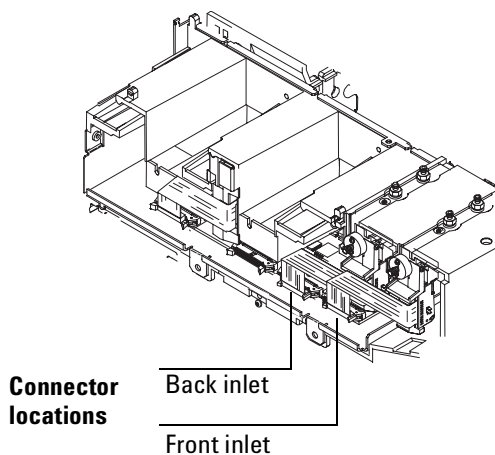

Installation  
**Installing the flow module**

3. Locate the ridges in the pneumatics carrier and the corresponding troughs in the flow manifold. Slide the flow module into the carrier, lining up the ridges and troughs.

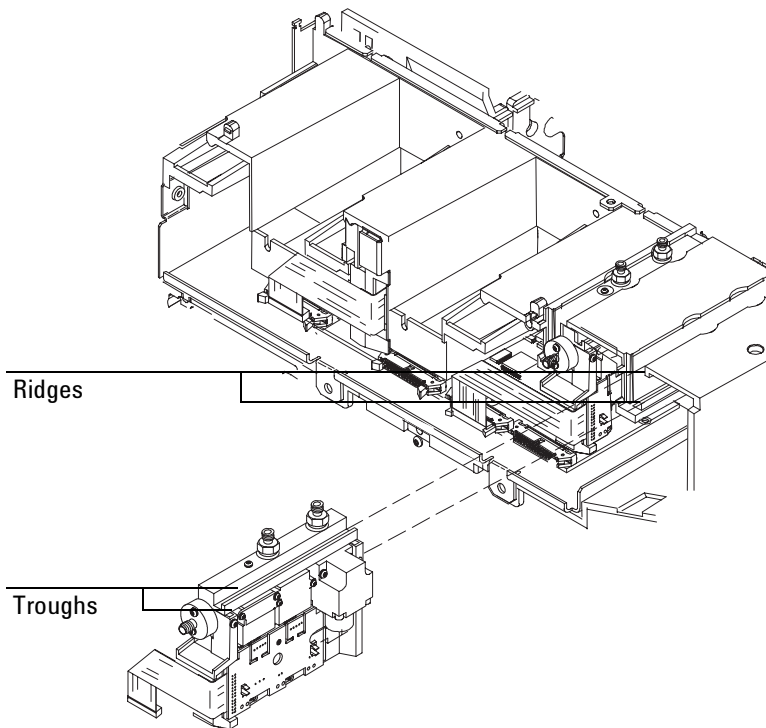

4. Fold the ribbon cable and plug into the appropriate connector. Push until the plug is firmly in place. Lock the connector by moving the tabs to the center of the connector until they click into place. Replug the front inlet ribbon cable into the front connector, if necessary.

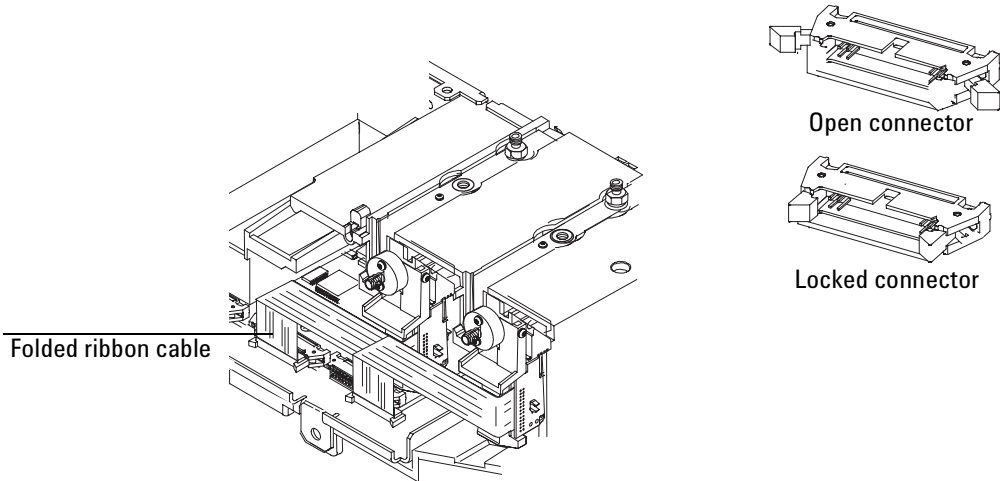

5. Install and tighten the screw at the top of the manifold. Tighten with a T-20 Torx screwdriver until snug.

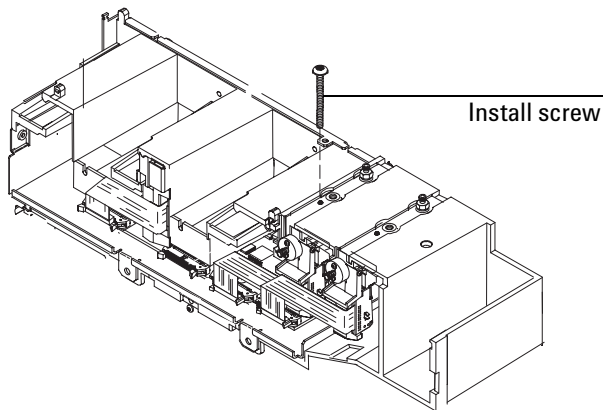

## Removing the insulation

1. From the front of the GC, locate the inlet chassis and the front and back inlet positions.

**Inlet chassis**

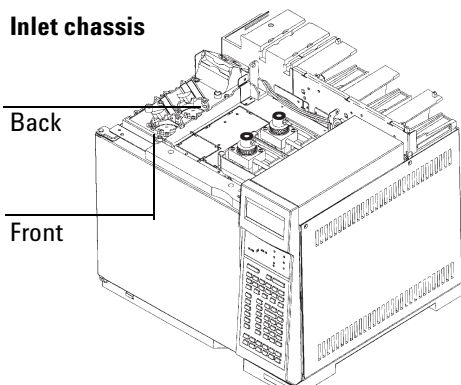

2. Remove the round metal cutout in the front or back inlet position, if necessary. Insert a flat-blade screwdriver into the slot in the cutout and move the screwdriver back and forth until the cutout breaks free from the sheet metal on the oven top.

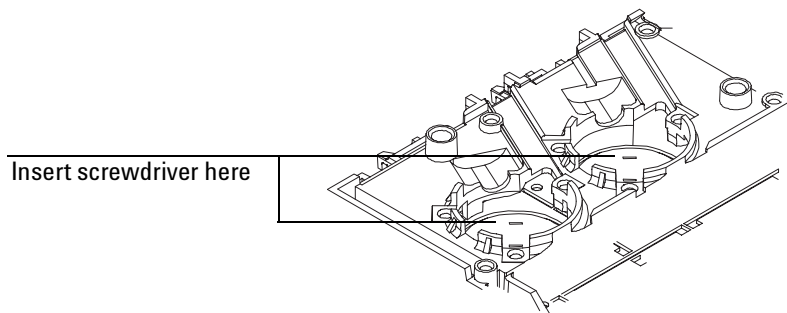

3. Remove the die-cut insulation plug from the front or back inlet position if necessary.

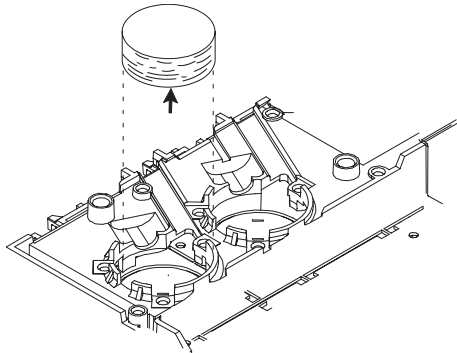

4. Carefully remove the scribed circle of insulation from the front or back inlet position to create an opening into the oven, if necessary.

**Method 1:** Use a sharp knife to cut out the insulation using the scribed circle as a guide.

**Method 2:** Pierce the insulation with a screwdriver. Rotate the screwdriver around the scribed circle to remove excess insulation.

Clean up any pieces of insulation that fall inside the oven.

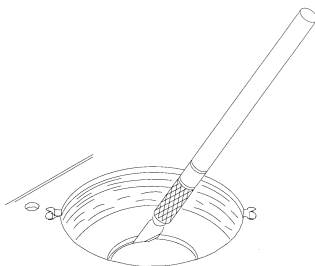

5. Place the insulation in the lower insulation cover.
6. From inside the oven, install the two heat-resistant screws in the cutouts adjacent to the inlet opening. Do not tighten the screws. Push the lower insulation cover over the front or back inlet until it is flush with the oven top and rotate it until the slots in the cup hook over the screws. Tighten the screws with a Torx T-20 screwdriver.

## Installing the interface

1. Place the bottom insulation in the inlet cavity.
2. Place the top insulation in the inlet cavity so that the cutouts in the insulation face the back of the GC.
3. Place the inlet in the insulated cavity so that the large nut and the heater/sensor cable are in the troughs in the inlet chassis and the three captive screws line up with the holes in the oven top.
4. Tighten each screw once with the T-20 Torx screwdriver until the inlet is properly aligned. Tighten each screw again until snug.

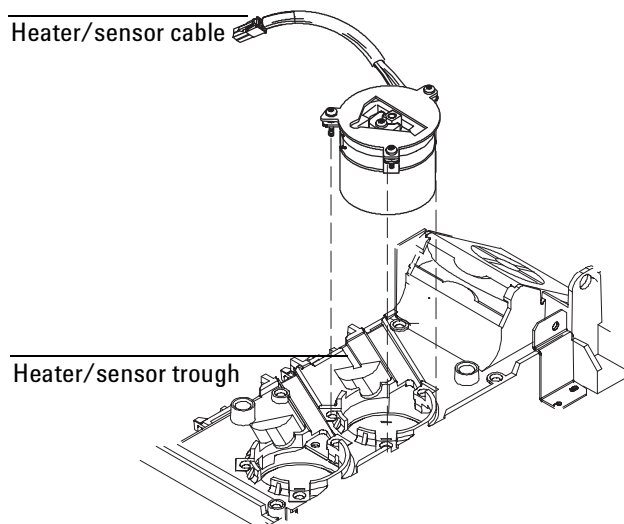

- From the left side of the GC, locate the heater/sensor wire and its corresponding connector. Tuck the heater/sensor wire underneath the clip at the side of the GC and connect it to the nearest square connector.

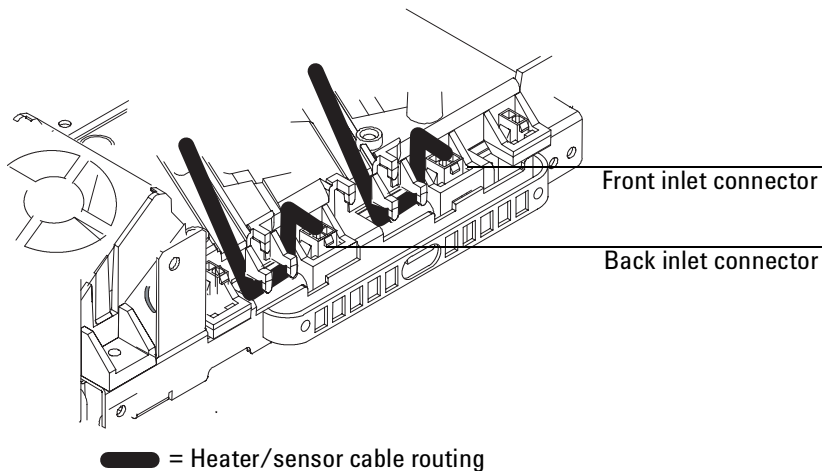

- Place the trap in the compartment at the end of the pneumatics carrier. Route the trap's copper tubing behind the fan bracket and to the inlet. Route the trap's stainless steel tubing behind the fan and to the flow manifold. Route the stainless steel tubing from the inlet to the flow manifold.

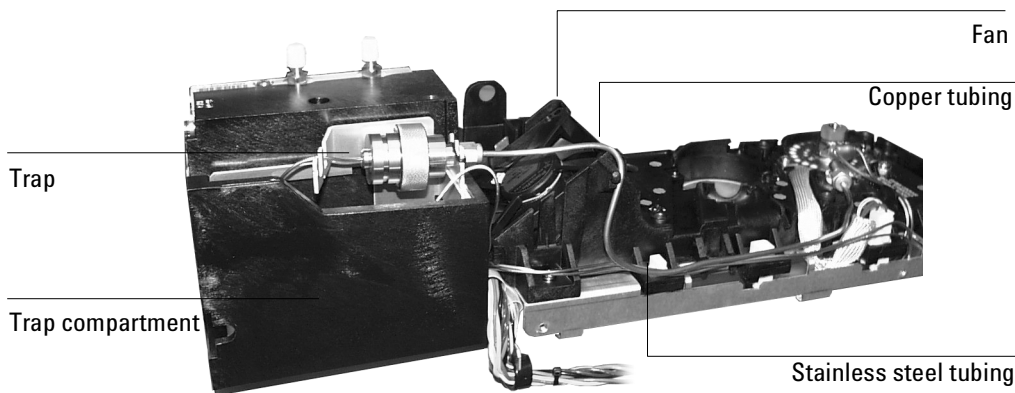

## Replace the ROMs

This step depends on which 6890 model and which firmware you have.

- **6890A, serial number less than US00005700.** These instruments are firmware-incompatible with the Volatiles Interface, unless the ROMs have been replaced as part of some other upgrade.

Determine the revision number of the ROMs on the main board as described below. If the ROMs in this kit are a later revision (higher number), replace the ROMs on the main board with those from the kit.

- **6890A, serial number US00005700 or greater.** These instruments are firmware-compatible with the Volatiles Interface.

Determine the revision number of the ROMs on the main board as described below. If the ROMs in this kit are a later revision (higher number), replace the ROMs on the main board with those from the kit.

- **6890N.** These instruments do not use ROMs. All firmware versions support the PTV inlets.

### To determine the firmware revision number

On the 6890 keyboard, press [Status], then [Clear].



## To change the ROMs, if necessary

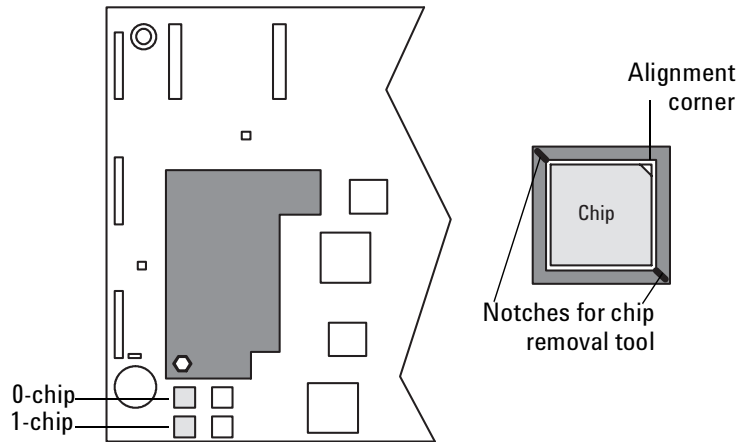

Examine the right side of the instrument. On the main board, just below the large cutout on the left, are four chip sockets. The two on the left contain the operating programs (firmware) that run the GC.

These two chips must be replaced with new ones that include software for the Volatiles Interface.

---

### Caution

This procedure requires precautions against electrostatic discharge. Use the grounded wrist strap (part no. 9300-1408) and connect it to a bare metal surface of the GC. Failure to heed this caution may result in damage to the instrument or to the Volatiles Interface assembly.

1. Use a chip removal tool with a gentle rocking/pulling motion to remove the chip in the top left socket.
2. Repeat with the bottom left chip and socket.
3. The new chips are identified by a part number, a version number, and a suffix of either “.0” or “.1”. They are referred to as the 0-chip and the 1-chip respectively.

---

### Caution

Before inserting a ROM, make sure that all of the prongs are straight. Use a small flat-blade screwdriver or needle-nose pliers to straighten prongs.

Installation  
**Replace the ROMs**

4. Note that each chip has one diagonal corner. This corner must be at the top right when the chip is inserted in its socket.
5. Install the 0-chip in the top left socket with the diagonal corner at the top right. Check that all of the prongs are aligned with their slots, then push the chip into the socket until it is firmly seated and level.
6. Similarly, install the 1-chip in the bottom left socket.

## Restoring the GC to operating condition

1. Reinstall the left and right side covers and tighten the screws.
2. Replace the fan cover.
3. Reinstall the detector cover.
4. Reinstall the inlet cover and tighten the five screws or reinstall the tray bracket. Make certain the heater/sensor wires and the stainless steel tubing are in their troughs so that they are not crushed by the cover.
5. Reinstall the upper rear panel and tighten the screws.
6. Reinstall the RFI cover.
7. Remove the labels that cover the vent holes in the pneumatics cover. From underneath the cover, push the labels through the top.

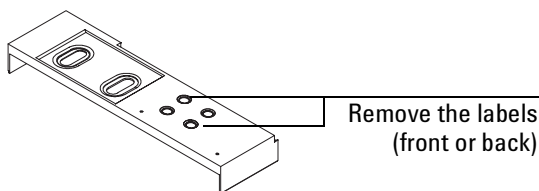

8. Replace the pneumatics cover.
9. Plug in the GC and turn it on.
10. Press [Front Inlet] or [Back Inlet]. You will see this display:

BACK INLET (VI)	
Mode:	Split
Temp	25 Off<
Pressure	0.x† Off
Split ratio	100
Split flow	Off
Tot flow	x.x† Off
Gas Saver	Off

† An actual flow and pressure value is displayed when the carrier gas is off or not connected. This is not an error. After the inlet is zeroed and operational, the actual flow and pressure values will be equal to the setpoint values. A split ratio is displayed when a capillary column is configured. If only temperature is displayed, check if EPC flow module is connected to the EPC control board.

## Calibrating your inlet

Your inlet's flow manifold contains a pressure sensor that can be zeroed after it is installed on your GC. This calibration procedure ensures an accurate inlet pressure display.

---

**Caution**

---

Do not connect the carrier gas to your flow manifold until you have zeroed your inlet's pressure sensor.

1. Plug in your GC and turn it on, if you haven't already done so.
2. Wait 15 minutes. This allows your GC to reach thermal equilibrium.
3. Zero the inlet's pressure sensor:
  - a. Press [Options], scroll to `Calibration` and press [Enter].
  - b. Scroll to `Front inlet` or `Back inlet` and press [Enter].
  - c. Scroll to `Pressure Zero`.
  - d. Press [On] to zero the pressure sensor.
4. Turn off your GC and unplug the power cord.
5. Plumb the carrier gas to your flow manifold. If you need help with this Step, see your GC installation instructions.
6. Plug in the GC again and turn it on.
7. Configure your GC's column and carrier gas. See *GC operating instructions* for details.





**Agilent Technologies**



Printed on recycled paper.



This product is recyclable.

©Agilent Technologies, Inc. 2001

Printed in USA DEC 2001



G2319-90107